

# Superior Hub Hybrid 2 user manual

Updated April 15, 2026



**Superior Hub Hybrid 2** is a hybrid control panel for an Ajax system, compatible with both wired and wireless Ajax devices. It controls connected device operation and interacts with both a user and a monitoring company. The control panel is also available as a board without casing. This version is called Superior Hub Hybrid 2 (without casing).

The hub requires internet access to connect to the Ajax Cloud server. Available communication channels are Ethernet and two SIM cards. For cellular connection, Superior Hub Hybrid 2 is equipped with a 2G/3G/4G (LTE) modem.

Superior Hub Hybrid 2 is equipped with two tamper sensors on the front and rear sides of the board, which protect the hub from dismantling. The device is powered by the 100–240 V~ mains and can also be powered by the 12 V<sub>DC</sub> backup battery.

[Buy Superior Hub Hybrid 2](#)

# Functional elements

## Casing elements

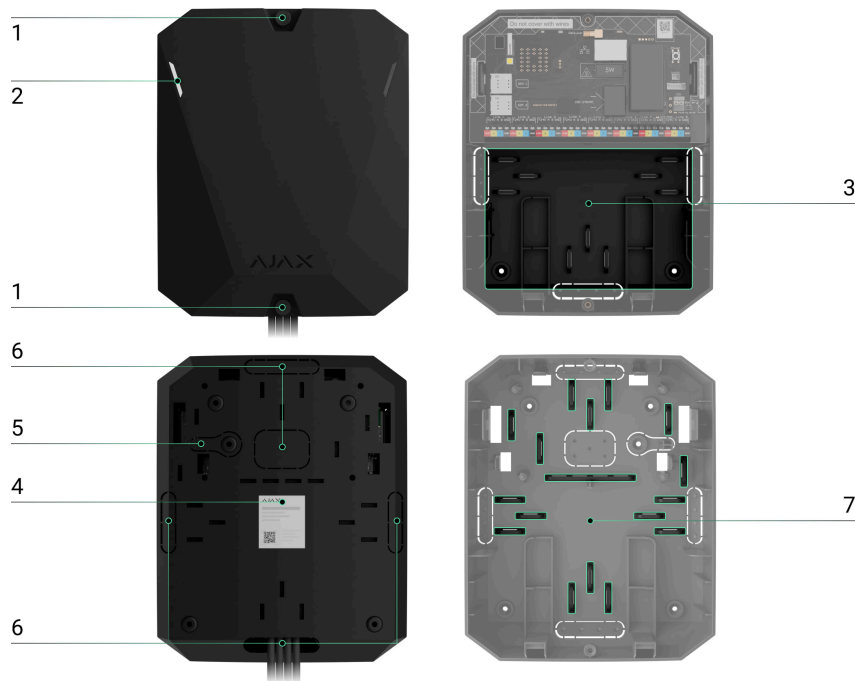

1. Screws to secure the casing lid. Use a bundled hexagon key ( $\varnothing$  4 mm) to unscrew them.
2. Light guide to indicate the hub state.
3. Part with holders for the backup battery.



The backup battery is not included.

4. QR code and ID (serial number) of the control panel.
5. Perforated part of the casing. It is necessary for the tamper button to be triggered in case of any attempt to detach the device from the surface. Do not break it off.
6. Perforated parts of the casing to route the wires of connected devices.

## 7. Cable fasteners.

# Board elements

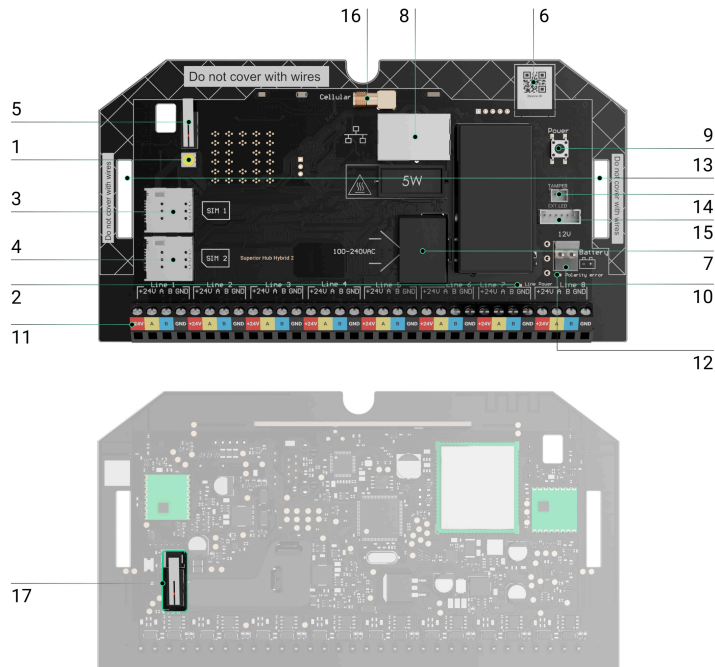

1. LED indicator to show the states of the hub and connected communication channels.
2. LED indicator to show the states of devices connected to the hub Fibra lines.
3. Slot for micro SIM 1.
4. Slot for micro SIM 2.
5. Front-side tamper button. It detects attempts to remove the casing lid of the control panel.
6. QR code and ID (serial number) of the device.
7. Power cable connector.
8. Ethernet cable connector.
9. Power button.
10. Terminals for connecting a 12 V backup battery.

11. Fibra line terminals for connecting wired devices.
12. Battery error indicator. It lights up if the battery is connected with reverse polarity (e.g., “-” is connected to “+” and vice versa).
13. Mounting holes to install the Superior Hub Hybrid 2 board into the casing.
14. Connector to attach the tamper board to the hub. The tamper board is included in the Case complete set, which is sold separately.
15. Connector to attach the external LED to the hub. The external LED is included in the Superior Hub Hybrid 2 complete set.
16. External antenna connector for the cellular communication channel (SMA female connector).
17. Rear-side tamper button. It signals attempts to detach the control panel casing from the surface.

## Fibra line terminals

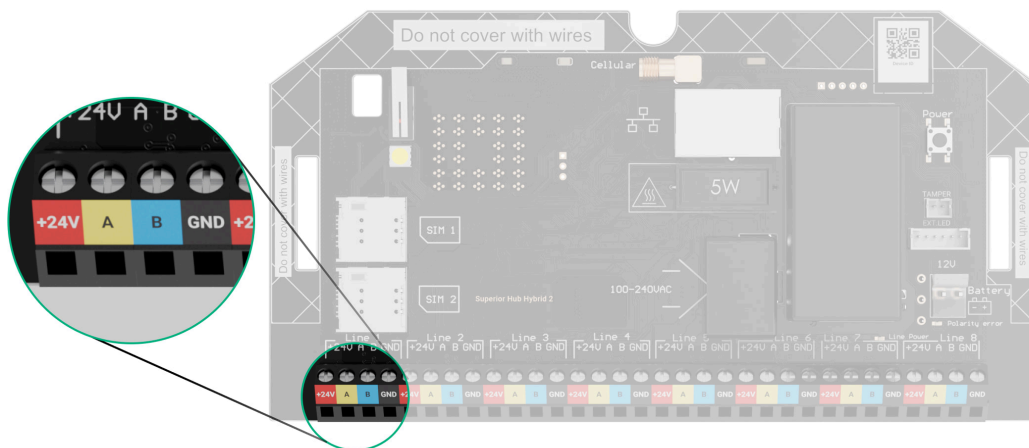

Superior Hub Hybrid 2 has 8 Fibra lines. Numbers from 1 to 8 are indicated on the control panel board.

### Fibra line terminals:

1. **+24 V** – power supply terminal of 24 V $\overline{=}$ .

2. **A** – first signal terminal.
3. **B** – second signal terminal.
4. **GND** – power ground terminal.



Observe the polarity and the order of connecting the wires when installing Fibra devices.

## Operating principle

0:00 / 0:12

Superior Hub Hybrid 2 is a hybrid control panel of the Ajax system. It controls the operation of connected devices. The hub is added to a space – a virtual entity where various autonomous devices are gathered on the same physical object.

### How to create a space

You can connect up to 250 wired and wireless Ajax devices to Superior Hub Hybrid 2. Connected devices protect against intrusion, fire, and flooding, and also allow you to control electrical appliances according to scenarios or manually – in a mobile app or by pressing the panic button, LightSwitch, or keypad with touch screen.

To monitor the operation of all security system devices, the hub communicates with the connected devices using three encrypted protocols:

1. **Jeweller** is a radio protocol for transmitting events and alarms from Ajax wireless devices. The communication range is up to 3,500 m without obstacles: walls, doors, or inter-floor constructions.

[Learn more about Jeweller](#)

2. **Wings** is a radio protocol for transmitting large data packets. The communication range is up to 3,000 m without obstacles: walls, doors, or inter-floor constructions.

[Learn more about Wings](#)

3. **Fibra** is a wired protocol for transmitting events and alarms from Ajax wired devices. The communication range is up to 2,000 m when connected via twisted pair U/UTP cat.5.

[Learn more about Fibra](#)

If a device is triggered, the system raises an alarm in less than a second, regardless of the communication protocol. In case of an alarm, the hub activates the sirens, starts the scenarios, and notifies the security company's monitoring station and all users.

## Sabotage protection

Superior Hub Hybrid 2 has 3 communication channels for connecting to the Ajax Cloud server: Ethernet and two SIM cards. This allows you to connect the device to three different communication providers at the same time. If one of the communication channels is unavailable, the hub will automatically switch to another one and inform the monitoring station of the security company and system users.

The connection between the hub and the devices added to it is protected by an advanced encryption scheme that ensures data confidentiality and integrity. This means that all sensitive data in a

message is encrypted, and each message includes a unique authentication tag allowing the system to verify that the data has not been modified during transmission. The system can reliably detect tampering and reject forged or altered messages, providing robust protection against both passive and active attacks. This ensures secure communication between the device and the hub, as well as reliable system and data protection.

### [Learn more about advanced encrypted communication](#)

Superior Hub Hybrid 2 uses **frequency hopping** for radio communication. With this method, the hub and devices added to it change their operating frequency according to a predefined pattern. The hopping sequence covers a defined set of channels within the operating bands, and the devices switch frequencies synchronously with the hub. Even if some channels are affected by jamming, messages can be transmitted successfully via other channels. Frequency hopping improves system reliability and performance, ensuring its resistance to intentional interference and jamming attempts.

Frequency hopping does not cause delays or pauses in radio communication and does not reduce data transfer speeds. If [range extenders](#) are added to the system, frequency hopping is used for “device ↔ range extender” and “range extender ↔ hub” radio communication.



The system uses frequency hopping for radio communication only if all wireless devices support this method.

If at least one device added to the system does not support frequency hopping, the hub and all devices switch to the operating frequencies of that device and do not use frequency hopping for radio communication.

### [Learn more about frequency hopping](#)

## [Learn more about jamming](#)

The hub regularly checks the quality of communication with all connected devices. If any device loses connection with the control panel, upon expiry of the time specified by the admin, all system users (depending on the settings), as well as the monitoring station of the security company, will receive a notification about the incident.

## [Learn more](#)

No one can turn off the hub unnoticed, even when the facility is disarmed. If an intruder tries to open the hub casing, the tamper will be triggered immediately. The alarm notification will be sent to the security company and to system users.

## [What is a tamper](#)

## [What is a tamper board](#)

The hub rechecks Ajax Cloud connection at regular intervals. The ping period is specified in the hub settings. If a minimum ping period is set, the server may notify the users and the security company in as little as 60 seconds after the connection is lost.

## [Learn more](#)

The backup battery can be connected to the hub, providing backup power for the hub and wired devices and ensuring system operability

for a specific period.

You can use batteries of a different capacity, which suit Case size and feature the full charging time of no more than 40 hours. The maximum battery charging current from the Superior Hub Hybrid 2 is 300 mA.

[Learn more](#)

## OS Malevich

Superior Hub Hybrid 2 is run by the real-time operating system OS Malevich. It is protected from viruses and cyber-attacks.

OS Malevich brings new features and functionality to the Ajax system through over-the-air updates. The update does not require the involvement of an installation engineer or user.

The update takes up to 2 minutes with the security system disarmed and the external power supply and backup battery connected.

[How OS Malevich updates](#)

## Ajax account

To set up the system, install the [Ajax PRO app](#) and log in to your PRO account or create a new one if you don't have one. Don't create a new account for each space since one account can manage multiple security systems. Where necessary, you can configure separate access rights for each space.

[How to register a PRO account](#)

User settings, systems, and parameters of connected devices are stored in the space. Changing the space admin, adding or removing users does not reset the settings of devices added to the space.



**Superior Hub Hybrid 2** can only be added and configured in Ajax PRO apps.

## Selecting the installation site

**Superior Hub Hybrid 2** must be installed on a vertical surface using bundled fasteners. All the necessary holes for fastening in the casing have already been made. The control panel is designed for indoor installation only. It is advisable to choose an installation site where the hub is hidden from prying eyes – for example, in a storage room. This helps to reduce the risk of sabotage or security system jamming.



Install the hub on a vertical surface. This will ensure proper tamper response if someone attempts to detach the hub. Learn the battery documentation before installing – some batteries can be mounted only vertically (with terminals upward). Another installation position could cause fast battery degradation.

Choose a location where the hub can use all possible communication channels: Ethernet and two SIM cards. Ensure that the cellular signal at the installation site is stable and reaches 2–3 bars. In areas with poor signal reception, it is recommended to install Ajax [ExternalAntenna](#). Correct device operation cannot be guaranteed if the cellular signal is weak.

When choosing an installation site, take into account the distance between the hub and wireless devices and the presence of obstacles between them hindering the radio signal passage: walls, intermediate floors, or large-size objects located in the room.

To roughly calculate the signal strength at the place of installation of wireless devices, use our [radio communication range calculator](#). Use [Fibra power supply calculator](#) to calculate the wired connection range.

Run the Jeweller, Wings, and Fibra signal strength tests. The stable signal strength of 2–3 bars with all connected devices should be provided at the

chosen installation site. With a signal strength of 1 or 0 bars, we do not guarantee stable operation of the security system.

If the system has devices with signal strength of 1 or 0 bars, consider relocating the hub or device. If this is not possible or the device still has low or unstable signal strength after being moved, use range extenders.

Follow these recommendations when designing the system project for a facility. Only professionals should design and install the Ajax system. The list of authorized Ajax partners is available here.

## Where not to install Superior Hub Hybrid 2

Outdoors. This could result in a failure of the control panel.

Near the metal objects and mirrors. They can cause attenuation or shielding of the radio signal. This could result in the loss of connection between the hub and wireless Ajax devices.

In places with high levels of radio interference. This could result in the loss of connection between the hub and wireless Ajax devices or false notifications about security system jamming.

Less than 1 meter away from the router and power cables. This could result in the loss of connection between the hub and wireless devices.

Less than 1 meter away from Jeweller devices. This could result in the loss of connection between the hub and these devices.

In places where the hub will have a signal strength of 1 or 0 bars with connected devices. This could result in the loss of connection between the hub and these devices.

Inside premises with temperature and humidity beyond the permissible limits. This could result in a failure of the control panel.

In places with no cellular signal or one-bar signal strength. In areas with poor signal reception, it is recommended to install Ajax ExternalAntenna. We do not guarantee correct operation of the device with a low cellular signal strength.

## Designing

It is crucial to design the system project properly to ensure the correct installation and configuration of the devices. The design must consider the number and types of devices at the facility, their exact locations and installation heights, the length of wired Fibra lines and cables from other devices, the type of cable used, and other parameters. Refer to the article to learn tips for designing the Fibra system project.

## Topologies

Fibra is a data transfer protocol for the Ajax wired devices. At the physical level, Fibra resembles a bus connection: the detectors are connected to the control panel using a four-core cable. Ajax systems support three topologies – **Beam (Radial wiring)**, **Ring**, and **Tree**. Learn more about topologies in [this article](#).

## Cable length and type

The maximum range of a wired connection using the **Beam (Radial wiring)** topology is 2,000 meters, and using the **Ring** topology – 500 meters.



Recommended cable types:

- U/UTP cat.5, 4 × 2 × 0.51 mm (24 AWG), copper conductor.
- Signal cable 4 × 0.22 mm<sup>2</sup>, copper conductor.

If you use a different type of cable, the communication range for wired connections may vary. No other types of cables have been tested.

## Verification using a calculator

To ensure that the project is designed correctly and the system functions as intended in practice, we have developed a [Fibra power supply calculator](#). It helps to check the communication quality and cable length for wired Fibra devices when designing the system project.

## Preparing for installation

### Cable arrangement

Before laying cables, check the electrical and fire safety regulations applicable in your region. Strictly follow these standards and regulations. Tips for cable arrangement are available in [this article](#).

## Cable routing

Before beginning the installation, we strongly advise you to review the [Device placement](#) section thoroughly. Stick to the outlined system project without deviation. Violation of the basic Superior Hub Hybrid 2 installation rules and the recommendations of this manual may lead to incorrect operation, as well as loss of connection with the device.

Signal cables of Fibra devices must be laid at a distance of at least 50 cm from the power cables when lying parallel, and, if they intersect, it must be at a 90° angle. Observe the permissible bend radius of the cable. It is specified by the manufacturer in the cable specifications. Otherwise, you risk damaging or breaking the conductor. Tips for cable routing are available in [this article](#).

## Preparing cables for connection

First, remove the insulation layer and strip the cable with a special insulation stripper. The ends of the wires inserted into the device terminals must be tinned or crimped with a sleeve. It ensures a reliable connection and protects the conductor from oxidation. Tips for preparing the cables are available in [this article](#).

## Installation



Before installing Superior Hub Hybrid 2 make sure that you have selected the optimal location and that it meets the requirements of this manual. To reduce the risk of sabotage, the cables must be hidden from view and located in a difficult place for intruders to access. Ideally, the cables should be mounted in walls, floors, or ceilings. Run the [Fibra signal strength test](#) **before final installation**.

When connecting to the terminals of the device, do not twist the wires together, but solder them. The ends of the wires that will be inserted into the terminals should be tinned or crimped with a special sleeve. This will ensure a reliable connection. **Observe the safety procedures and the rules**

**for electrical installation work when connecting the control panel and wired devices.**

**To install Superior Hub Hybrid 2 using the default casing:**

1. Prepare holes for routing the cables in advance by carefully breaking off the perforated parts of the Superior Hub Hybrid 2 casing.

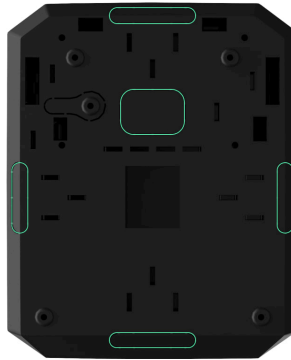

2. Pull the power and Ethernet cables into the casing through the prepared holes.
3. Secure the casing on the vertical surface at the selected installation location with the bundled screws using all fixing points. One of them is in the perforated part above the tamper button. This fixing point is required for the tamper button to be triggered in case of any attempt to detach the hub casing.

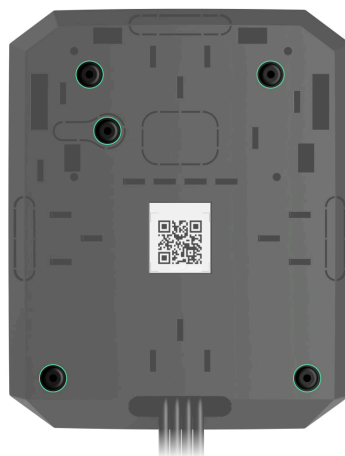

4. Place the Superior Hub Hybrid 2 board into the casing on the holders.

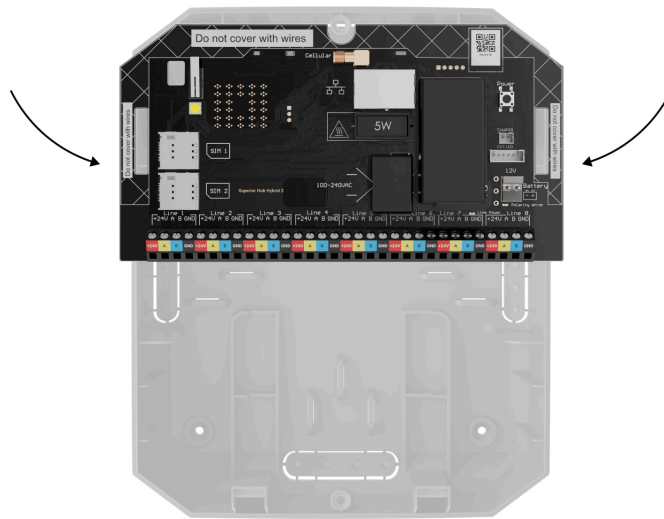

5. If necessary, connect Ajax ExternalAntenna to the appropriate communication port.



Use only Ajax ExternalAntenna. We do not guarantee correct device operation if a third-party external antenna is used. Before installation, read the ExternalAntenna user manual.

6. Install the battery in the designated holders provided in the casing.
7. Connect the backup battery to the appropriate hub terminal using the bundled cable. Follow the correct polarity and wire connection order.

Note: Superior Hub Hybrid 2 cannot be connected to third-party power supply units.



Use a 12 V<sub>DC</sub> battery with a capacity of 4, 7, or 9 A·h. The maximum dimensions of the battery that can be installed in the casing are 151 × 65 × 94 mm, and the weight is 5 kg. Special holders are provided in the hub casing for this battery configuration. You can use batteries of different capacities if they fit in size and the charging time does not exceed 40 hours. The maximum battery charging current from Superior Hub Hybrid 2 is 300 mA.

8. Connect the power and Ethernet cables to the appropriate connectors.

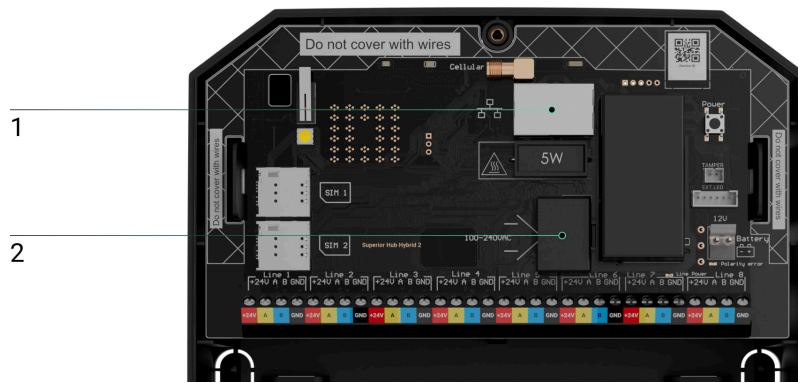

- 1 – Ethernet cable connector.
- 2 – power cable connector.



To comply with [INCERT requirements](#), use the screw terminal block adapter to connect an external power supply.

9. Secure the cables with ties.

10. Install SIM cards:

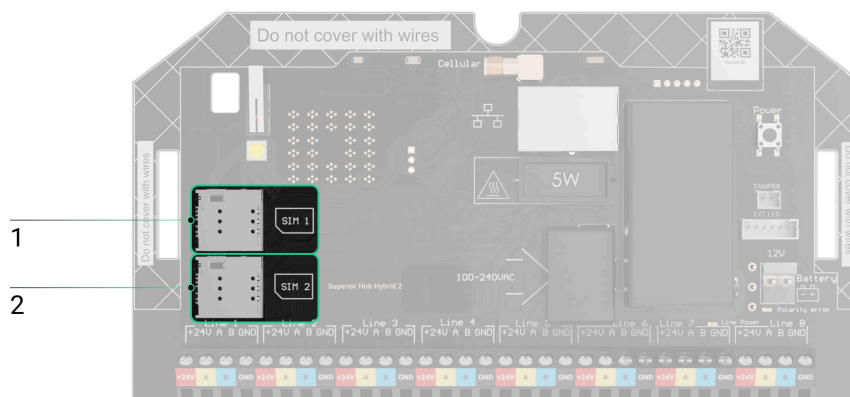

- 1 – slot for micro SIM 1.
- 2 – slot for micro SIM 2.

11. Press and hold the hub's power button. Once the hub turns on, the Fibra line LEDs on the hub board will light up.

12. Install the lid on the hub casing and fix it with the bundled screws.

13. Add the hub to a space.

14. Check the state of the hub casing in the Ajax PRO app. If a tamper alarm is indicated, ensure that the hub casing is closed tightly.

## If Ethernet connection fails

If the Ethernet connection is not established, disable proxy and MAC address filtration and activate DHCP in the router settings. The hub will automatically receive an IP address. After that, you can assign a static IP address to the hub in the Ajax app.

## If SIM connection fails

To connect to the cellular network, you need to install a micro SIM card with a PIN code request disabled and a sufficient amount of funds on the account to pay for services as per the operator's tariff. To disable the PIN code request, insert the SIM card into the phone.

If the hub fails to connect to the cellular network, use Ethernet to configure the network parameters: roaming, APN access point, user name, and password. To find out these parameters, contact the support service of your mobile operator.

### How to set or change APN settings in the hub

## Adding a hub to the Ajax app



Use the latest versions of Ajax apps to access all available features and ensure proper system operation. Superior Hub Hybrid 2 can only be added and configured in Ajax PRO apps.

After adding a hub to your account, you become the admin of the device. Admins can invite other users to the system and determine their rights. You can connect up to 200 users to Superior Hub Hybrid 2.

Each PRO account connected to the hub, as well as the security company profile, is considered a user of the system.

Changing or removing the admin from the list of hub users does not reset the settings of the system or connected devices.



If there are already users on the hub, the hub admin, PRO with the rights to configure the system, or the installation company maintaining the selected hub can add your account. You will be notified that the hub has already been added to another account. Contact our [Technical Support](#) to determine who has admin rights on the hub.

[User account types and rights](#)

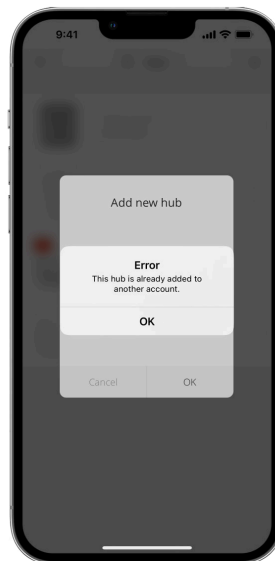

### To add a hub to the [Ajax PRO app](#):

1. Connect external power, backup battery, Ethernet, and/or SIM cards to the hub.
2. Turn on the hub and wait until the connection status LED indicator lights up green or white.

3. Open the [Ajax PRO app](#). Allow the app to access the requested features. This will allow you to fully use the capabilities of the Ajax apps and not to miss notifications about alarms or events.
4. Ensure you have a space. Create the space if you don't have one.

### What is a space

### How to create a space

5. Click **Add Hub**.
6. Choose a suitable method: **manually** or using a **step-by-step guidance**. If you are setting the system up for the first time, use step-by-step guidance.

## **Manually** **By step-by-step guidance**

---

### **To add a hub manually:**

- Assign the hub name.
- Scan the hub QR code or enter the ID manually.
- Wait until the hub is added. After binding, the hub will be displayed in the **Devices**  tab of the [Ajax PRO app](#).

## **Preparing to connect devices**

Create at least one [virtual room](#) before adding devices to the system. Rooms are needed to group devices and to increase the information content of notifications. Names of devices and rooms are displayed in the text of events and alarms of the Ajax system.

## **Wireless device connection**

**To add a wireless device to the hub, in the [Ajax PRO app](#):**

1. Go to the **Devices**  tab and tap **Add device**.
2. Assign a name to the device.
3. Scan the QR code or enter the device ID manually. A QR code with ID is placed on the device enclosure. Also, it is duplicated on the device packaging.
4. Select a virtual room and a security group (if the group mode is enabled).
5. Tap **Add**, and the countdown will begin.
6. Follow the instructions in the app to connect the device.
7. Repeat steps 1–6 to add any required devices.

To add a device to the hub, the device should be located within the hub's radio communication range – at the same secured premises.

## Wired device connection

Fibra wired communication technology allows creating segments up to 2,000 meters long. Superior Hub Hybrid 2 features 8 lines compatible with all Fibra devices, regardless of the type. Security detectors, keypads, and sirens are connected to the same line and ensure the safety of a specific area of the facility.

## Installation and connection



Before installing the devices, make sure that you have selected the optimal location and that it meets the conditions of the user manual. Wires must be hidden from view and located in a place that is difficult for intruders to access to reduce the likelihood of sabotage. Ideally, the wires should be set into the walls, floor, and/or ceiling. Before the final installation, test the Fibra signal strength.

**To connect a wired device to the hub:**

1. De-energize and turn off the hub. Disconnect the backup battery.

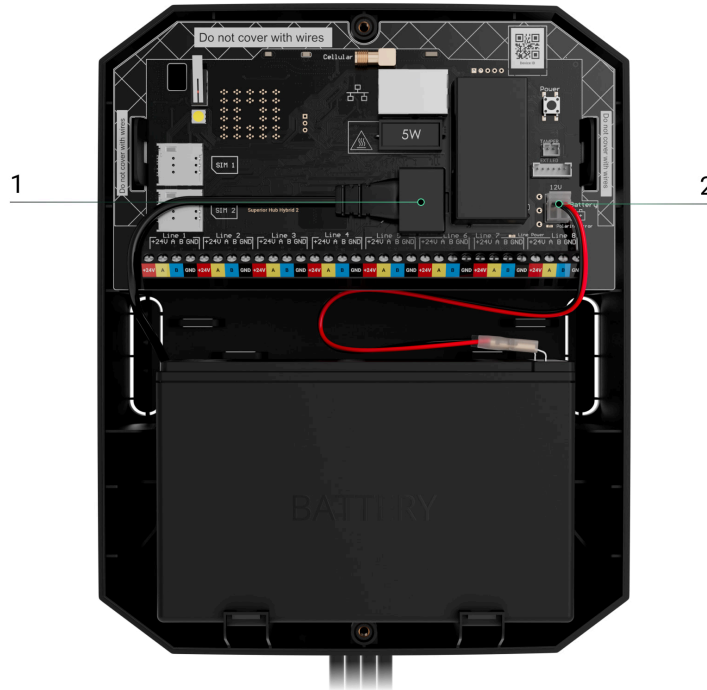

1 – external power supply.

2 – backup battery.

2. Run the four-wire cables into the casing. Connect the wires to Superior Hub Hybrid 2 line terminals:

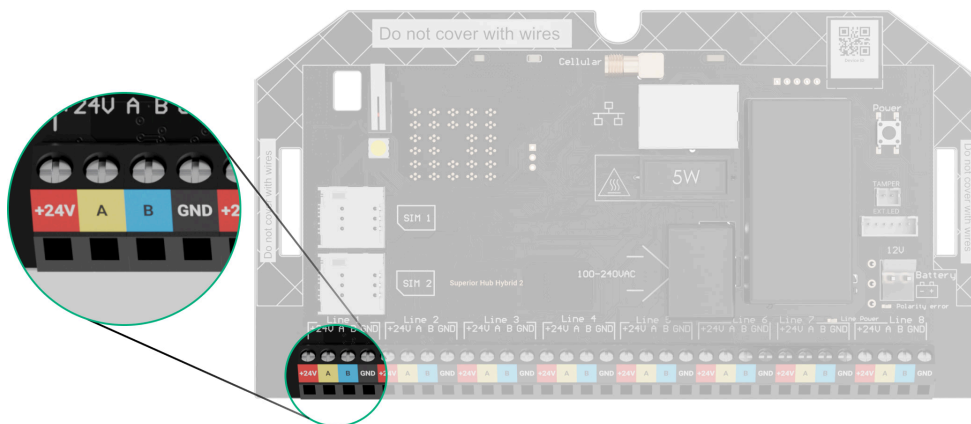

**+24V** – power supply terminal of 24 V $\overline{\text{=}}$ .

**A, B** – signal terminals.

**GND** – ground.

3. Connect the other end of the four-wire cable to the terminals of the first device in the line, observing the polarity and the order of wiring. Securely fasten the cable to the terminals of the device.
4. If other devices are connected to the segment, prepare and wire the cable for the next device into the terminals.

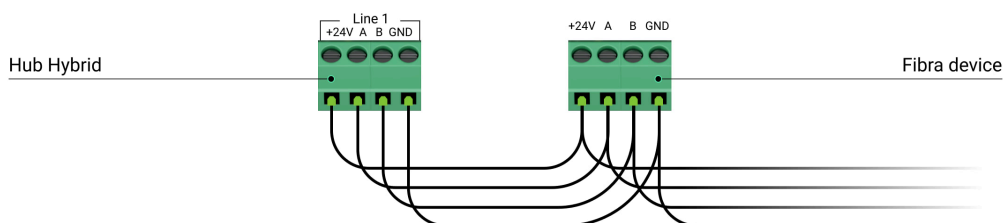

**+24V** – power supply terminal of 24 V<sub>DC</sub>.

**A, B** – signal terminals.

**GND** – ground.

5. Connect other devices to the line, if necessary.
6. Install a 120 ohm terminating resistor for the last device in the line using the **Beam (Radial) topology**. A terminating resistor is installed between terminals A and B of the last device in the line.

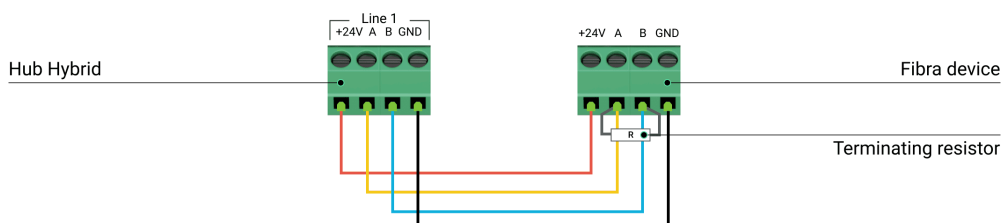

With the **Ring topology**, a terminating resistor is not needed. In this case, connect the last device in the line to the next Fibra line of the hub.



The nominal value of terminating resistors is 120 Ω. Termination resistors are included in the complete set of Superior Hub Hybrid 2.

## Learn more about connection methods

7. Connect power to the hub and turn it on.
8. Add devices to the system manually or using line scanning.
9. Run the Fibra signal strength test for each connected device. The recommended signal strength is two or three bars. Otherwise, check the connection and integrity of the wires or relocate the system devices.

## Adding wired devices

Two ways to add devices are available in the Ajax PRO app: **manually** and **automatically**. It is useful to add a few devices manually – for example, when replacing a faulty detector with a new one. Automatic line scanning is useful when adding numerous devices.

### Manually Automatically

---

#### To add a device manually:

1. Open the Ajax PRO app. Select the hub to which you want to add the device.
2. Go to the **Devices**  tab and tap **Add device**.
3. Assign a name to the device.
4. Scan the QR code or enter the device ID manually. A QR code with ID is placed on the device enclosure. Also, it is duplicated on the device packaging.

5. Select a virtual room and a security group (if the group mode is enabled).

6. Tap **Add**.

The device connected to the hub will appear in the list of hub devices in the Ajax app.



Device status updating depends on the Fibra settings; the default value is 36 seconds.

For the installation engineer to name the device correctly or assign a room and a group to it, we have provided two methods for device identification: by LED indication and by triggering an alarm.

### **By blinking    By triggering**

---

After line scanning, the Ajax PRO app will display a list of wired devices connected to the hub.

Click on any device in this list. After clicking, the LED indicator of the device will start blinking. After identifying the device, bind it to the hub.

### **To add a device to a hub:**

1. Click on the device in the list.
2. Assign a name to the device.
3. Specify a room and a group if the group mode is turned on.
4. Click **Save**.
5. The paired device will disappear from the list of devices available to be added.

If the hub already has the maximum number of devices added (for Superior Hub Hybrid 2, the default number is 250 in total and 200 wired devices per one Fibra line), you will receive an error notification when you try to add more devices.

Connected Ajax devices work with one hub only. Once added to a new hub, these devices are not removed from the list of devices of the old hub. This must be done through the Ajax PRO app.

## Fault counter

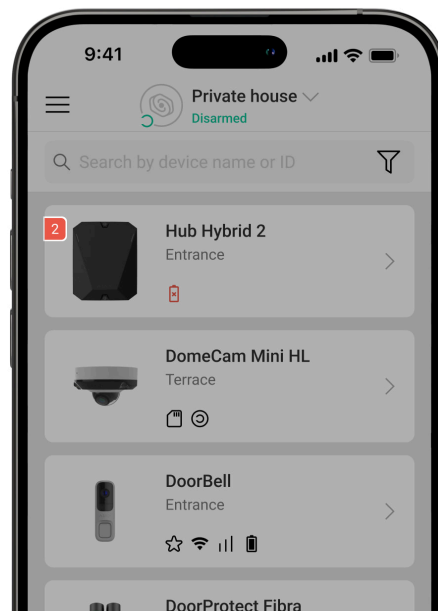







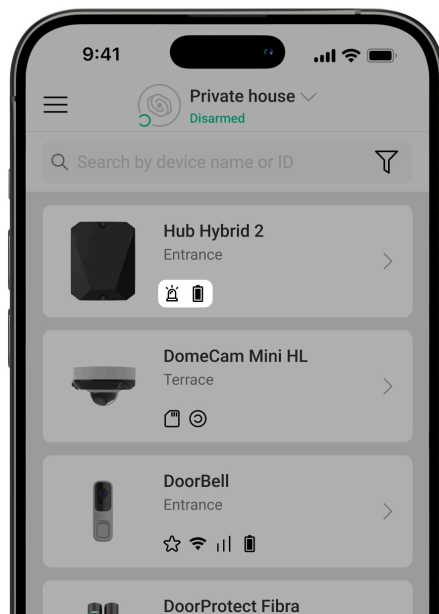



If a hub fault is detected (e.g., no external power supply is available), a fault counter is displayed on the device icon in the Ajax app.

All faults can be viewed in the hub states. Fields with faults will be highlighted in red.

## Icons



Icons display some of the Superior Hub Hybrid 2 statuses. You can view them in the Ajax app, in the **Devices**  tab.

Icon	Meaning
	The extra services are activated according to the subscription.  <a href="#">Learn more</a>
	The hub operates in the 2G network.
	The hub operates in the 3G network.
	The hub operates in the 4G (LTE) network.
	No SIM cards. Insert at least one SIM card.
	The SIM card is faulty or has a PIN code set up. Check SIM card operation in the phone and disable the PIN code request.
	The hub battery charge level. Displayed in 1% increments.
	The backup battery is not connected.
	Superior Hub Hybrid 2 malfunction detected. Open <a href="#">hub states</a> for details.
	The hub is directly connected to the monitoring station of the security company. The icon is not displayed if direct connection is not available or not configured.

	<a href="#"><u>Learn more</u></a>
	<p>The hub is not directly connected to the central monitoring station of the security company. The icon is not displayed if direct connection is not available or not configured.</p> <p><a href="#"><u>Learn more</u></a></p>
<span style="border: 1px solid red; border-radius: 5px; padding: 2px;">Saving mode</span>	The hub is in the <b>Saving mode</b> state.
<span style="border: 1px solid red; border-radius: 5px; padding: 2px;">Offline</span>	The hub has lost connection with the Ajax Cloud server.

## States

States can be found in the [Ajax app](#):

1. Go to the **Devices**  tab.
2. Select **Superior Hub Hybrid 2** from the list.

Parameter	Meaning
Malfunction	<p>Click the  button to open the list of Superior Hub Hybrid 2 malfunctions.</p> <p>The field appears only if a malfunction is detected.</p>
Cellular signal strength	<p>The signal strength of the active SIM mobile network.</p> <p>Install the hub in places where the cellular communication level reaches 2–3 bars. In areas with poor signal reception, it is recommended to install Ajax <a href="#"><u>ExternalAntenna</u></a>.</p> <p>If the hub is installed in a place with weak or unstable signal strength, it will not be able</p>

	<p>to call or send an SMS about an event or alarm.</p>
<p>External antenna for cellular</p>	<p>External antenna connection status:</p> <ul style="list-style-type: none"> <li>• <b>Connected</b> – the antenna is connected to a cellular port.</li> <li>• <b>Not connected</b> – the antenna is not connected to a cellular port.</li> <li>• <b>Damaged</b> – the antenna is broken.</li> </ul> <div style="border: 1px solid black; border-radius: 10px; padding: 10px; margin-top: 10px;"> <p> Detection of the external antenna breakage is possible only when the hub casing is closed properly.</p> </div>
<p>Connection</p>	<p>The status of connection between the hub and Ajax Cloud:</p> <ul style="list-style-type: none"> <li>• <b>Online</b> – the hub is connected to Ajax Cloud.</li> <li>• <b>Offline</b> – the hub is not connected to Ajax Cloud. Check the hub Internet connection.</li> </ul> <p>If Superior Hub Hybrid 2 is not connected to the server, the icons of the hub and all connected devices become semi-transparent in the list of devices.</p>
<p>Battery charge</p>	<p>Hub backup battery charge level. Displayed in 1% increments.</p> <p>At a charge level of 20% and below, the hub will report low battery charge.</p> <p><b><u><a href="#">Learn more</a></u></b></p>



Lid	<p>The status of the tamper that respond to dismantling or opening of Case:</p> <ul style="list-style-type: none"> <li>• <b>Closed</b> – the Case lid is closed. Normal state of Case.</li> <li>• <b>Open</b> – the Case lid is open or its integrity is otherwise compromised. Check the state of Case.</li> </ul> <p><a href="#"><u>Learn more</u></a></p>
Tamper board	<p>State of the Case's tamper board connected to the hub board:</p> <ul style="list-style-type: none"> <li>• <b>Not connected</b> – the tamper board is not connected to the hub.</li> <li>• <b>Connected</b> – the tamper board is connected to the hub.</li> </ul>
Lines power supply	<p>Power supply status on the hub Fibra lines:</p> <ul style="list-style-type: none"> <li>• <b>On</b> – power supply is provided to all Fibra lines.</li> <li>• <b>Off</b> – power supply is not provided to all Fibra lines.</li> </ul>
External power	<p>External power supply connection status:</p> <ul style="list-style-type: none"> <li>• <b>Connected</b> – the hub is connected to an external power supply.</li> <li>• <b>Disconnected</b> – no external power supply. Check the connection of the Superior Hub Hybrid 2 to the external power supply.</li> </ul>
Cellular data	<p>Mobile Internet connection status of the hub:</p> <ul style="list-style-type: none"> <li>• <b>Connected</b> – the hub is connected to Ajax Cloud via mobile Internet.</li> </ul>

	<ul style="list-style-type: none"> <li>• <b>Not connected</b> – the hub is not connected to Ajax Cloud via mobile Internet. Check the Superior Hub Hybrid 2 connection to the Internet via the mobile network.</li> <li>• <b>Disabled</b> – the option is disabled in the hub settings.</li> </ul> <p>If the cellular signal strength reaches 1–3 bars, and the hub has enough funds and/or has bonus SMS/calls, it will be able to call and send SMS, even if this field displays the <b>Not connected</b> status.</p>
Ethernet	<p>Internet connection status of the hub via Ethernet:</p> <ul style="list-style-type: none"> <li>• <b>Connected</b> – the hub is connected to Ajax Cloud via Ethernet. Normal state.</li> <li>• <b>Not connected</b> – the hub is not connected to Ajax Cloud via Ethernet. Check the Superior Hub Hybrid 2 connection to the Internet via the wired Internet.</li> <li>• <b>Disabled</b> – the option is disabled in the hub settings.</li> </ul>
SIM 1	<p>The number of the SIM card installed in the first slot.</p> <p>To copy the number, click on it.</p> <p>If the phone number is displayed as an <b>Unknown number</b>, the operator has not written it to the memory of the SIM card.</p>

SIM 2	<p>The number of the SIM card installed in the second slot.</p> <p>To copy the number, click on it.</p> <p>If the phone number is displayed as an <b>Unknown number</b>, the operator has not written it to the memory of the SIM card.</p>
Average noise (dBm)	<p>Average noise in the radio channel. Measured in the place where the hub is installed.</p> <p>The first two values show the level at Jeweller frequencies, and the third – at Wings frequencies.</p> <p>The acceptable value is –80 dBm or lower. For example, –95 dBm is considered acceptable and –70 dBm is invalid.</p> <p><b><u>What is security system jamming</u></b></p>
Hub model	<p>Hub model name.</p> <p><b><u>Differences between Ajax hubs</u></b></p>
Hardware	<p>Superior Hub Hybrid 2 hardware version. Not updated.</p>
Firmware	<p>Superior Hub Hybrid 2 firmware version. Updates remotely.</p> <p><b><u>Learn more</u></b></p>
Device ID	<p>Identifier (first 8 digits of the serial number) of the Superior Hub Hybrid 2.</p> <p>The identifier is located on the device box and on the board under the QR code.</p>
IMEI	<p>A unique 15-digit serial number for identifying the hub's modem on a GSM network. It is shown only when a SIM card is installed in the hub.</p>

# Settings

The control panel settings can be changed in Ajax PRO apps. In order to change the settings:

1. Log in to the [Ajax PRO apps](#).
2. Select an object from the list.
3. Go to the **Devices**  tab.
4. Select a hub.
5. Go to its **Settings** by clicking on the gear icon .
6. Select a settings category and make changes. After making changes, click **Back** to save the new settings.

**Name** 

**Room** 

**Select casing** 

**Ethernet** 

**Cellular** 

**Keypad access codes** 

**Code length restrictions** 

**Security schedule** 

<b>Detection zone test</b>	▼
<b>Jeweller/Fibra</b>	▼
<b>Telephony settings</b>	▼
<b>Lines</b>	▼
<b>Service</b>	▼
<b>User manual</b>	▼
<b>Transfer settings to another hub</b>	▼
<b>Remove hub</b>	▼

## **Hub settings reset**

Resetting the hub to the factory settings:

1. Turn on the hub if it is off.
2. Remove all users and installers from the hub.
3. Hold the power button for 30 s – the LED indicator on the hub board will start blinking red.
4. Remove the hub from your account.

## **Space settings**

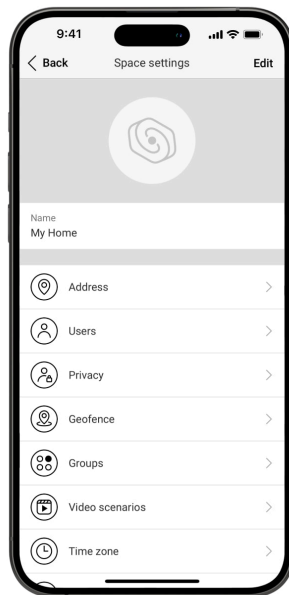

In the space settings, you can configure the following:

- **Image and name**
- **Address**
- **Users**
- **Privacy**
- **Geofence**
- **Groups**
- **Video scenarios**
- **Time zone**
- **Security companies**
- **Installers/Companies**

Settings can be changed in the [Ajax app](#):

1. Select the space if you have several of them or if you are using an Ajax PRO app.
2. Go to the **Control**  tab.

3. Go to **Settings** by tapping the gear icon  in the bottom right corner.
4. Set the required parameters.
5. Tap **Back** to save the new settings.

### How to configure a space

## Indication

Hub has two LED indication modes:

- **Hub – server connection.**
- **British disco.**

## Hub – server connection

**Hub – server connection** mode is enabled by default. The hub LED has a list of indications showing the system state or events occurring. Superior Hub Hybrid 2 can light up red, white, purple, yellow, blue, or green, depending on the state.

Superior Hub Hybrid 2 states can also be monitored in the Ajax apps.

Indication	Event	Note
Lights up white.	At least two communication channels are connected: Ethernet and one or two SIM cards.	When operating on a backup battery only, the indicator will blink every 10 seconds.
Lights up green.	One communication channel is connected: Ethernet or one/two SIM cards.  <a href="#"><u>Learn more</u></a>	When operating on a backup battery only, the indicator will blink every 10 seconds.

Lights up red.	The hub has no connection to the Internet or the Ajax Cloud service.	When operating on a backup battery only, the indicator will blink every 10 seconds.
The external power supply is disconnected  (if there is a connected backup battery).	Lights up continuously for 3 minutes, then blinks every 10 seconds.	The color of the indication depends on the number of connected communication channels.



If you see an indication while using the system that is not listed in this user manual, please contact the [Ajax support service](#).

## Access to indications

Superior Hub Hybrid 2 users can see the **British disco** indication after they:

- Arm/disarm the system using the Ajax keypad.
- Enter the correct user ID or personal code on the keypad and perform an action that has already been performed (for example, the system is disarmed and the disarm button is pressed on the keypad).
- Press the Ajax SpaceControl Jeweller button to arm/disarm the system or activate **Night mode**.
- Arm/disarm the system using Ajax apps.



All users can see the **Changing hub's state** indication.



## British disco

The function can be enabled in the hub settings in the Ajax PRO app (Hub → Settings → Services → LED indication).

Indication	Event	Note
<b>Changing hub's state</b>		
White LED flashes once per second.	<b>Two-stage arming</b> or <b>Delay when leaving</b> .	One of the devices is performing <b>Two-stage arming</b> or <b>Delay when leaving</b> .
Green LED flashes once per second.	Entry indication.	One of the devices is performing <b>Delay when entering</b> .
White LED lights up for 2 seconds.	Arming is completed.	The hub (or one of the groups) is changing its state from <b>Disarmed</b> to <b>Armed</b> .
Green LED lights up for 2 seconds.	Disarming is completed.	The hub (or one of the groups) is changing its state from <b>Armed</b> to <b>Disarmed</b> .
<b>Alerts and Malfunctions</b>		
Red and purple LED flashes in sequence for 5 seconds.	Confirmed hold-up alarm.	<p>There is an unrestored state after a confirmed hold-up alarm.</p> <div style="border: 1px solid black; border-radius: 10px; padding: 10px; margin-top: 10px;">  <p>The indication is displayed only if <b>Restoration after confirmed hold-up alarm</b> is enabled in the settings.</p> </div>
Red LED lights up for 5 seconds.	Hold-up alarm.	There is an unrestored state after a hold-up alarm.

		<div data-bbox="1050 85 1114 145" data-label="Image"></div> <p data-bbox="1161 85 1337 353">The indication is not displayed if there is a confirmed hold-up alarm state.</p>
		<div data-bbox="1050 526 1114 586" data-label="Image"></div> <p data-bbox="1161 526 1337 878">The indication is displayed only if <b>Restoration after hold-up alarm</b> is enabled in the settings.</p>
<p data-bbox="220 1205 434 1236">Red LED flashes.</p>	<p data-bbox="619 1102 976 1339">The number of flashes equals the Device No. of a hold-up device (DoubleButton Jeweller), the first to generate the hold-up alarm.</p>	<p data-bbox="1018 1169 1369 1281">There is an unrestored state after the confirmed or unconfirmed hold-up alarm.</p>

<p>Yellow and purple LED flashes sequentially for 5 seconds.</p>	<p>Confirmed intrusion alarm.</p>	<p>There is an unrestored state after the confirmed intrusion alarm.</p> <div data-bbox="1018 286 1374 792"><p>The indication is displayed only if <b>Restoration after confirmed intrusion alarm</b> is enabled in the settings.</p></div>
<p>Yellow LED lights up for 5 seconds.</p>	<p>Intrusion alarm.</p>	<p>There is an unrestored state after the intrusion alarm.</p> <div data-bbox="1018 1104 1374 1489"><p>The indication is not displayed if there is a confirmed intrusion alarm condition.</p></div> <div data-bbox="1018 1585 1374 2051"><p>The indication is displayed only if <b>Restoration after intrusion alarm</b> is enabled in the settings.</p></div>

<p>Yellow LED flashes.</p>	<p>The number of flashes equals the Device No. that first generated the intrusion alarm.</p>	<p>There is an unrestored state after the confirmed or unconfirmed intrusion alarm.</p>
<p>Red and blue LED flashes in sequence for 5 seconds.</p>	<p>Lid opening.</p>	<p>There is an unrestored tamper state or an open lid on any of the devices, or the hub.</p> <div data-bbox="1018 533 1374 958" style="border: 1px solid black; border-radius: 10px; padding: 10px; margin-top: 10px;">  <p>The indication is displayed only if <b>Restoration after Lid opening</b> is turned on in the settings.</p> </div>
<p>Yellow and blue LED flashes in sequence for 5 seconds.</p>	<p>Other malfunctions.</p>	<p>There is an unrestored fault state or a malfunction of any device or the hub.</p> <div data-bbox="1018 1310 1374 1697" style="border: 1px solid black; border-radius: 10px; padding: 10px; margin-top: 10px;">  <p>The indication is displayed only if <b>Restoration after faults</b> is enabled in the settings.</p> </div> <div data-bbox="1018 1792 1374 2060" style="border: 1px solid black; border-radius: 10px; padding: 10px; margin-top: 10px;">  <p>Currently, <b>Restoration after faults</b> is not available in Ajax apps.</p> </div>

Dark blue LED lights up for 5 seconds.	Temporary deactivation.	One of the devices is temporarily deactivated or the lid state notifications are disabled.
Blue LED lights up for 5 seconds.	Automatic deactivation.	One of the devices is automatically deactivated by an opening timer or the number of detections.
Green and blue LED flashes in sequence.	Alarm timer expiration. <a href="#"><u>Learn more about Alarm confirmation feature</u></a>	Displayed after the alarm timer expires (to confirm the alarm).

When nothing is happening in the system (no alarm, malfunction, lid opening, etc.), the LED displays two hub states:

- Armed/partially armed or **Night mode** enabled – the LED lights up white.
- Disarmed – the LED lights up green.

## Alert indication

If the system is disarmed and any of the indications from the table is present, the yellow LED flashes once per second.



If there are several states in the system, the indications are displayed one by one, in the same sequence as shown in the table.

## Additional features

## Video surveillance

Superior Hub Hybrid 2 is compatible with [Ajax cameras and NVRs](#) and with third-party cameras that support RTSP protocol or SDK integration.

### [How to connect cameras to the Ajax system](#)

You can calculate the number of cameras and NVRs that can be added to the space using the [video device calculator](#).

## Scenarios

Superior Hub Hybrid 2 allows creating 64 scenarios and minimizing the human factor impact on safety. The hub can manage the security of the entire facility or group according to a schedule; activate the smoke machine if intruders enter the room; de-energize the room and turn on emergency lighting in case of fire; shut off water in the event of a leak; control lighting devices, electric locks, roller shutters, and garage doors – when changing the security mode by pressing a button or by a detector alarm.

Scenarios can be used to reduce the number of routine actions and increase productivity. Ajax automation devices respond to changes in temperature and air quality. For example, configure the heating to turn on at low temperatures, control the supply system, humidifier, and air conditioner to maintain a comfortable climate.

### [How to create and customize a scenario](#)

## Photo verification



Superior Hub Hybrid 2 supports both MotionCam and MotionCam Outdoor motion detectors. When triggered, the detectors take a series of shots you can use to evaluate the unfolding of the events at the facility over time. This relieves users of unnecessary anxiety and prevents security companies from sending unnecessary patrol dispatches.

The detector activates the camera when armed and detects movement. Only users with access to the events feed, as well as authorized employees of the security company can see visual alarm verifications provided that the security system is connected to the monitoring station.

If **Photo on demand** function is activated, the detectors can take a photo upon the command of a system user or PRO user with the appropriate rights. The taking of a photo is always registered in the hub's events feed.

The shots are protected by encryption at every stage of transmission. They are stored on the Ajax Cloud server and are not processed or analysed.

[Learn more](#)

## Maintenance

Check the functioning of Superior Hub Hybrid 2 and connected devices on a regular basis. The optimal frequency of checks is once every three

months. Clean the hub casing from dust, cobwebs, and other contaminants as they emerge. Use a soft, dry cloth that is suitable for equipment care.

Do not use substances that contain alcohol, acetone, petrol, and other active solvents to clean the device.

## Defined support period

We release security updates for hubs for at least two years of the warranty period.

## Technical specifications

[All technical specifications](#)

[Compliance with standards](#)

[INCERT installation compliance](#)

[Setup in compliance with EN requirements](#)

## Warranty

Warranty for the Limited Liability Company “Ajax Systems Manufacturing” products is valid for 2 years after the purchase.

If the device does not operate properly, we recommend contacting Ajax Technical Support first. In most cases, technical issues can be resolved remotely.

[Warranty obligations](#)

[User Agreement](#)

## Contact Technical Support:

- [e-mail](#)
- [Telegram](#)

Manufactured by "AS Manufacturing" LLC